

# Light-metal rerailing systems

for all rail vehicles

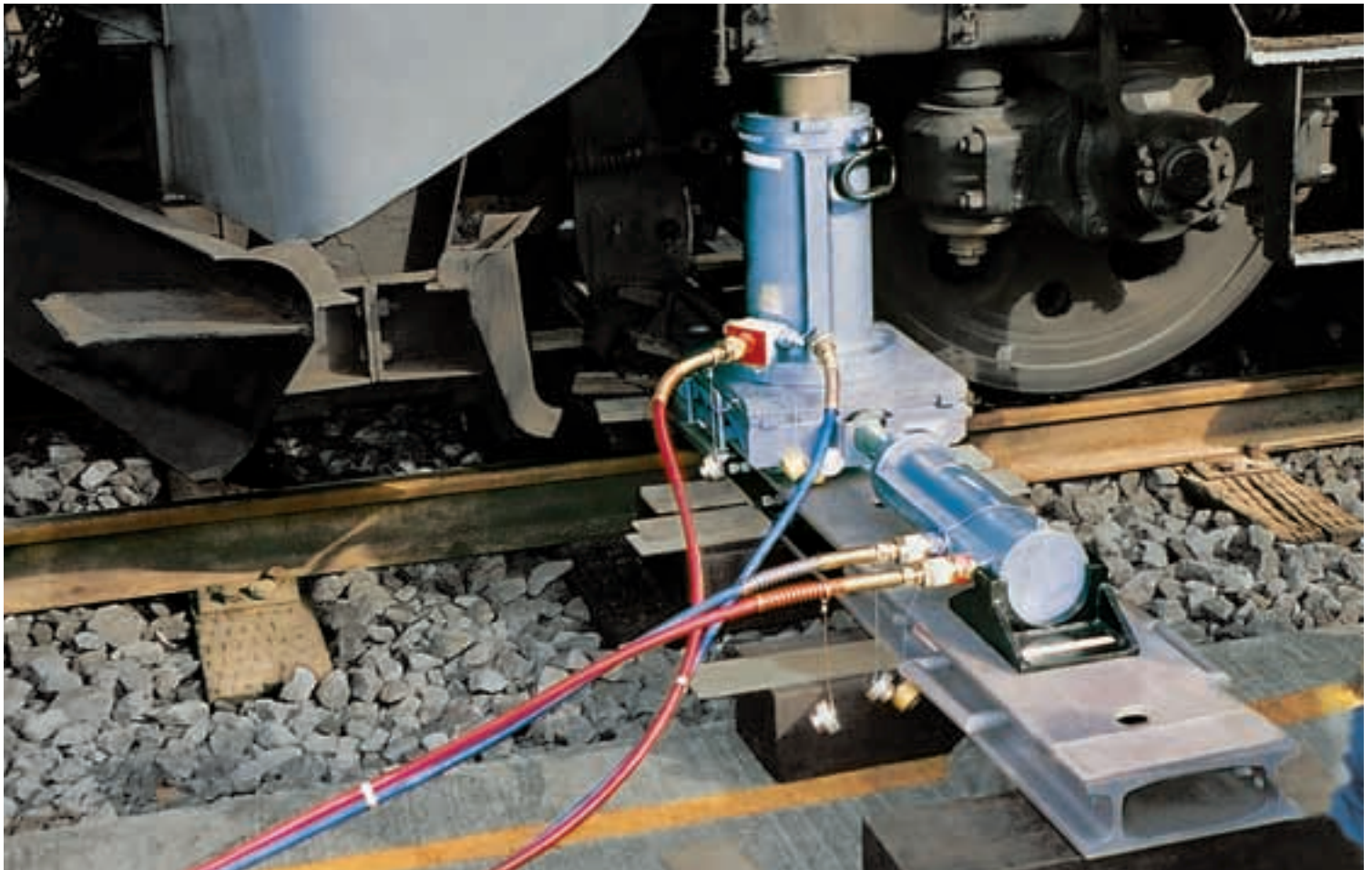

IKEMA spol. s.r.o. tel.: +421 (2) 4599 4876  
Tabaková 2 e-mail: ikema@ikema.sk  
900 27 Bernolákovo [www.ikema.sk](http://www.ikema.sk)  
SLOVAKIA



...technology in motion

Hegenscheidt  MFD

# Hegenscheidt-MFD light-metal rerailing systems safe, reliable and robust, for all rail vehicles



# Contents

<b>02</b>	<b>Hydraulic drive systems</b> <ul style="list-style-type: none"><li>• Drive system with combustion engine</li><li>• Drive system with combustion engine and control unit</li><li>• Drive system with electric motor</li><li>• Drive system with electric motor and control unit</li><li>• Drive system hand pump</li><li>• Drive system for carrier vehicle</li></ul>	Page 06 - 09
<b>03</b>	<b>Control unit</b> <ul style="list-style-type: none"><li>• Control unit</li></ul>	Page 09
<b>04</b>	<b>Hydraulic jacks</b> <ul style="list-style-type: none"><li>• Lifting jack series 400</li><li>• Lifting jack series 600</li><li>• Lifting jack series 900</li><li>• Lifting jack series 1000</li><li>• Lifting jack series 1200</li><li>• Other lifting jacks</li></ul>	Page 10 - 15
<b>05</b>	<b>Equipment for lateral displacement</b> <ul style="list-style-type: none"><li>• Rerailing bridge and bridge coupling</li><li>• Roller carriages</li><li>• Displacing jacks</li><li>• Distance bar</li><li>• Accessories for lateral displacement</li></ul>	Page 16 - 19
<b>06</b>	<b>Equipment for uprighting</b>	Page 20 - 21
<b>07</b>	<b>Haulage device</b>	Page 21
<b>08</b>	<b>Auxiliary Tow-Trucks</b> <ul style="list-style-type: none"><li>• Auxiliary tow-trucks</li></ul>	Page 22
<b>09</b>	<b>Accessories</b> <ul style="list-style-type: none"><li>• Axle pusher</li><li>• High-pressure hose</li><li>• Hose couplings</li><li>• Distribution valve</li><li>• Bogie suspension</li></ul>	Page 23 - 25
<b>10</b>	<b>Carrier vehicles</b>	Page 25
<b>11</b>	<b>Rescue equipment and accessories</b> <ul style="list-style-type: none"><li>• Rescue device (cutters/spreaders, pump)</li><li>• Accessories</li></ul>	Page 26
<b>12</b>	<b>Air bags and accessories</b> <ul style="list-style-type: none"><li>• Air bags, compressors</li><li>• Accessories</li></ul>	Page 27

# The light-metal rerailing system from Hegenscheidt-MFD

## High level of safety and simplicity of handling

For over 100 years Hegenscheidt-MFD has been partner of the rail industry. The acknowledged high quality of Hegenscheidt-MFD rail engineering rests on many years of unbroken close collaboration with the world's leading railway organisations. Intensive dedication to the search for solutions to the problems of rail transportation meant that as early as 1926 rerailing equipment had been developed now forms the basis for rerailing technology throughout the world today.

In more than 100 countries Hegenscheidt-MFD rerailing equipment is currently making a contribution to rail transportation.

Hegenscheidt-MFD rerailing equipment also uses the double-acting re-pressure system which has proved itself throughout the entire field of industrial hydraulics. This system makes it possible to lift, lower, push or pull with millimetre accuracy. Optimisation of safety is evidenced in the monitoring and correction features.

The individual components of Hegenscheidt-MFD rerailing technology have been matched to each other in their design, lifting height, load-bearing capacity and performance in such a way that they can be regarded as state of the art in the field of railway engineering.

The system has been designed so that, depending on how the components are put together, any rail vehicle (tram, subway or railway carriage, locomotive or traction unit, smelting plant vehicle and also the very heaviest transfer ladle car) can be uprighted and rerailed. The system is also particularly suitable for moving bridges and other heavy loads. The Hegenscheidt-MFD rerailing system can also be used on single-track sections. In the case of multiple track sections there is no blocking of the secondary track while in electrified sections no dismantling of overhead contact lines is required.

Hegenscheidt-MFD applies the very highest safety requirements to the rerailing system. Ease of operation, simplicity in handling, robustness and stability under load underline this.

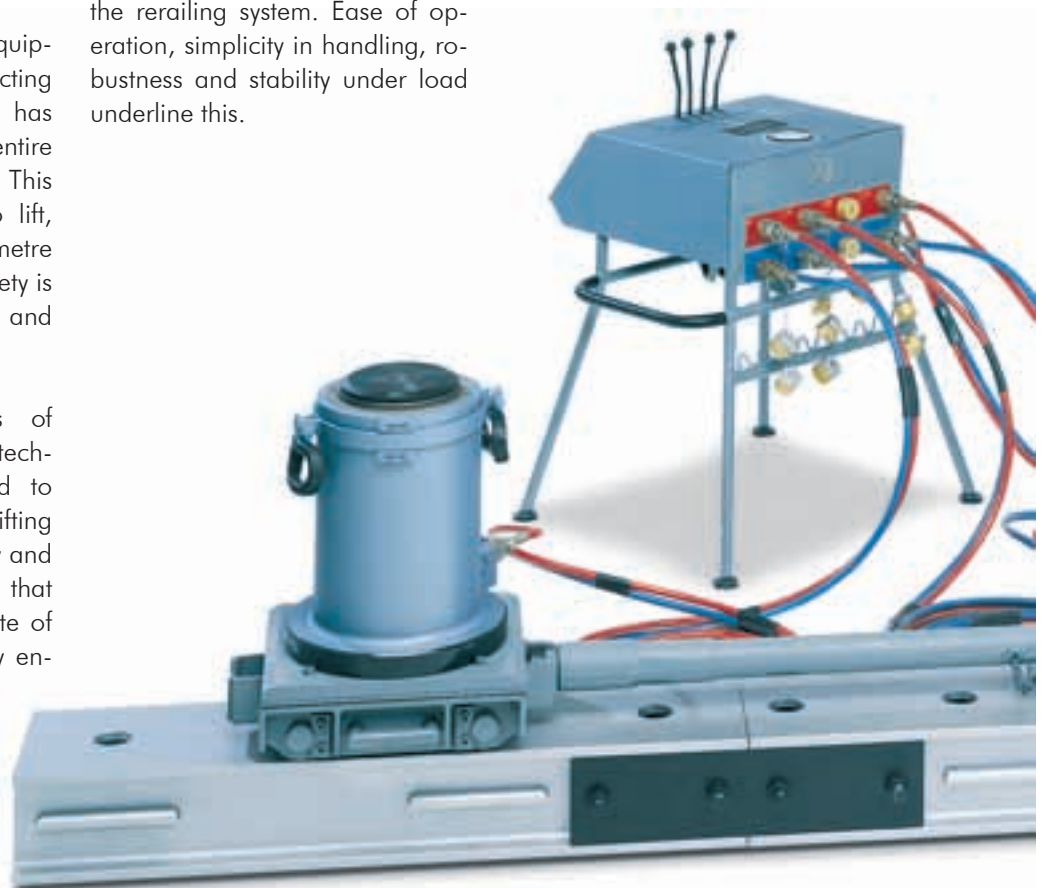

## Special features

- Double-acting hydraulic re-pressure system (30 MPa)
- Fully controllable lifting, lowering, pushing, pulling, accurate to the mm.
- High stability of jacks under load due to integrated bottom flange
- Hydraulically releasable non-return valves to secure the load against accidental lowering in event of pressure loss (e.g., hose severance)
- Protection of the jacks against overload or misoperation by means of two integrated overload valves per jack
- Jerk-free operation of the jacks even under full load
- Reduced wear due to roller-burnished and hard-anodised contact surfaces
- Computer-calculated designs and use of high-strength light-metal alloy
- Extensive, integrated range of lifting jacks covering all normally occurring types of application
- Reliable and safe functioning of the system even at extreme temperatures from  $-40\text{ }^{\circ}\text{C}$  to  $+70\text{ }^{\circ}\text{C}$
- Easy and fast connection of individual components by means of manually connectable threaded hose couplings with positive colour coding
- No oil leakage during coupling or uncoupling of the jacks
- Coupling and uncoupling is also possible under load
- Lightweight rerailing bridges made from computer-calculated profile sections with optimised static and dynamic properties
- Entire system can be operated by one man from the control unit which means that personnel need not enter the load area
- Integrated control "dead man control" which ensures that each control valve immediately and automatically goes into the neutral position as soon as the operator releases the lever, this is essential for safety reasons.
- Pneumatically operated airbags by connecting to a compressor with its own drive (combustion or electric motor)
- Hydraulically operated rescue gear (cutters, spreaders) by connecting to a pump with its own drive (combustion engine or electric motor)
- All components of the system have been weight-optimised and are therefore light and compact
- All equipment is GS-proved.

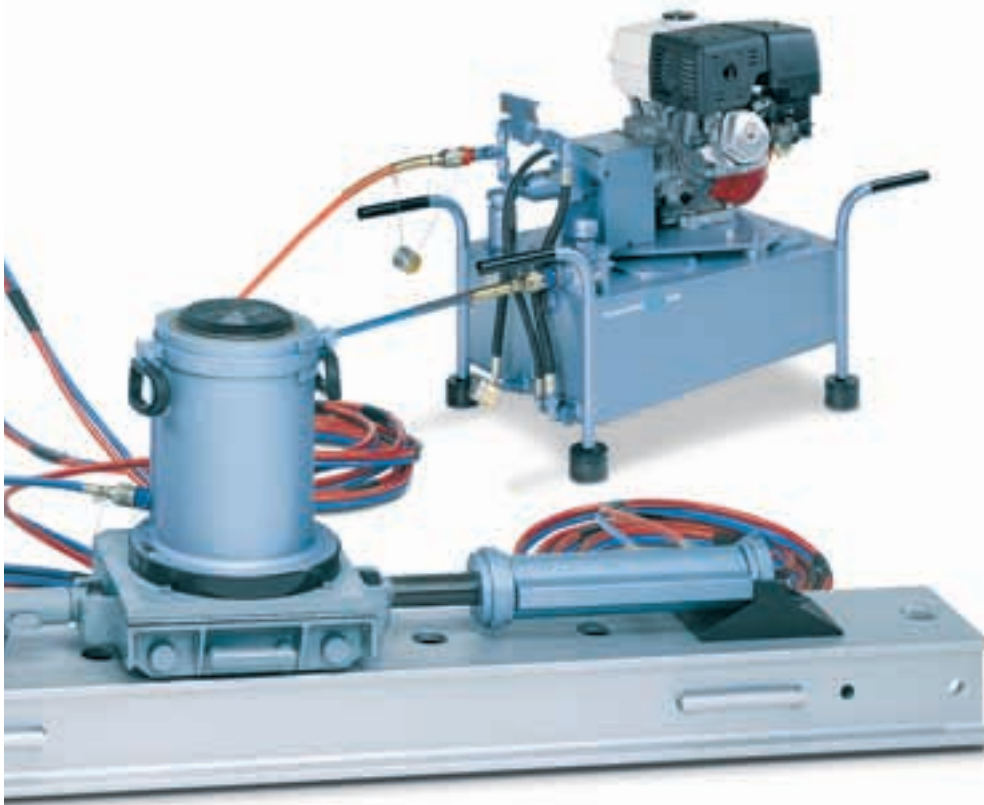

## 2 Hydraulic drive systems



Drive systems with combustion engine									
Pump unit with	Order no.:	Engine power kW	Output l/min	Oil capacity l	Useable capacity l	Length mm	Width mm	Height mm	Weight** kg
Diesel engine (large)*	<b>02-6000</b>	6,3	8,6	68	60	1160	570	896	108
Petrol engine (large)*	<b>02-4000</b>	8,1	8,8	68	60	1160	570	785	93
Petrol engine (small)	<b>02-4020</b>	2,9	3,1	25	20	1000	485	618	48

\* Also available with electric starter

\*\* Excluding oil

The drive systems generate the requisite hydraulic operating pressure of 30 MPa. Drive systems with control block control and monitor all movement sequences of the rerailing process. Our range is divided into two sizes: small pump sets with a useful capacity of 20 l oil and large pump sets with 60 l. The small pump sets have been specially developed for the light-weight vehicles used by mass transit systems - in other words, they have a smaller oil capacity and lower weight.



Drive system with combustion engine and control unit									
Pump unit with	Order no.:	Engine power kW	Output l/min	Oil capacity l	Useable capacity l	Length mm	Width mm	Height mm	Weight* kg
Petrol engine 3-fold control block (small)	<b>02-4320</b>	2,9	3,1	25	20	1000	485	874	77

\* Excluding oil



02-8000

Drive systems with electric motor*									
Pump unit with	Order no.:	Engine power kW	Output l/min	Oil capacity l	Useable capacity l	Length mm	Width mm	Height mm	Weight** kg
Electric motor (large) (400/230 V - three-phase current)	<b>02-8000</b>	4	7,4	68	60	1160	570	900	100
Electric motor (small) (230 V - alternative current)	<b>02-8020</b>	1,5	2,5	25	20	1000	485	533	55



02-8400



02-8420

Drive systems with electric motor and control block*									
Pump unit with	Order no.:	Engine power kW	Output l/min	Oil capacity l	Useable capacity l	Length mm	Width mm	Height mm	Weight** kg
Electric motor (large) (400/230 V - three-phase current) 4-fold control block	<b>02-8400</b>	4	7,4	68	60	1160	570	1200	132
Electric motor (small) (230 V - alternating current) 2-fold control block	<b>02-8220</b>	1,5	2,5	25	20	1000	485	874	71
Electric motor (small) (230 V - alternating current) 3-fold control block	<b>02-8320</b>	1,5	2,5	25	20	1000	485	874	74
Electric motor (small) (230 V - alternating current) 4-fold control block	<b>02-8420</b>	1,5	2,5	25	20	1000	485	874	76

\*Power generators available on request

\*\*Excluding oil

## 2 Hydraulic drive system

### Hand pump

The hand pump is a complete unit for use in minor rerailling operations, especially where no separate power supply is available or when a pump set with combustion engine cannot be used due, for example, to the risk of explosion.

Due to the re-pressure system the hand pump can perform all functions such as lifting, lowering, pushing and pulling without restriction and with a full working pressure of 30 MPa.

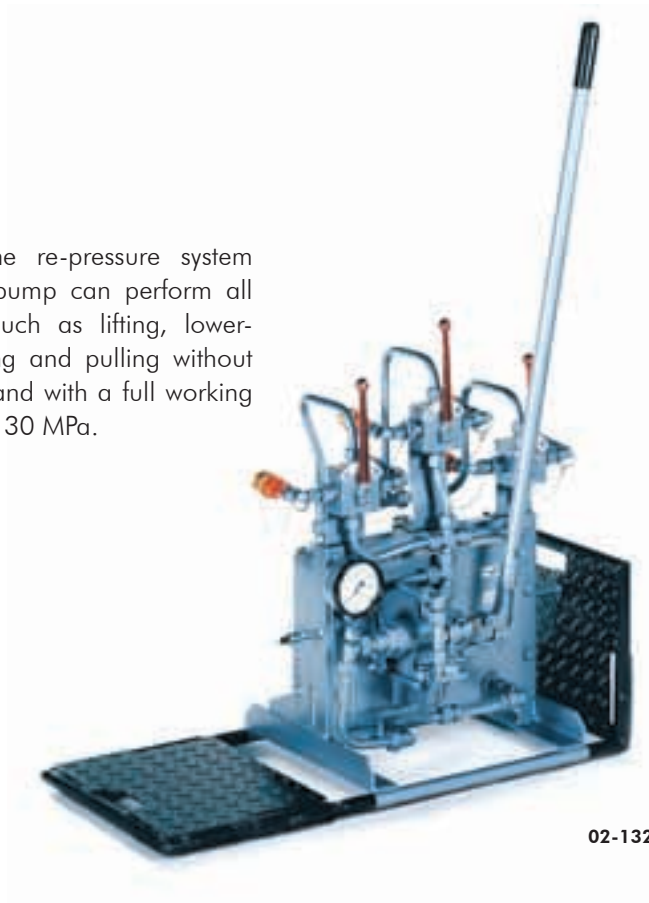

02-1320



02-2120

### Emergency hand pump

This hand pump is used primarily as emergency equipment to make rerailling possible in cases where no pump set is available. All necessary rerailling functions can be carried out at a full operating pressure of 30 MPa.

Drive system: hand pumps								
Hand pump	Order no.:	Output cm <sup>3</sup> / double stroke	Oil capacity l	Useable capacity l	Lenght working/transport mm	Width mm	Height mm	Weight** kg
2 Connection/ 20 l	02-1220	35	20	18	1300/680	450	730	68
2 Connection/ 30 l	02-1230	35	30	28	1300/680	450	730	75
3 Connection/ 20 l	02-1320	35	20	18	1300/680	450	730	70
3 Connection/ 30 l	02-1330	35	30	28	1300/680	450	730	77
Emergency hand pump 1 connection / 20l	02-2120	16	20	18	800	300	380	26

\*\*Excluding oil



## Add-on hydraulic unit

The add-on hydraulic unit (30 MPa) specially designed by Hengerscheidt-MFD is intended to be mounted on a carrier vehicle. The axial piston pump of the add-on hydraulic unit is driven from the power take-off shaft of the carrier vehicle. Connection to the hydraulic components and the control system is effected via the add-on hydraulic unit. (see equipment group 10, p. 25)

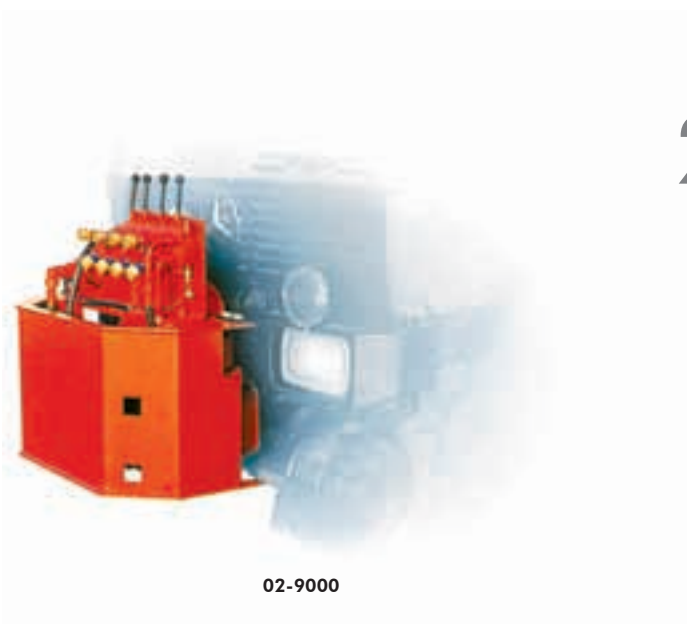

02-9000

### Drive system for carrier vehicle

	Order no.:	Output l/min	Oil capacity l	Useable capacity l	Length mm	Width mm	Height mm	Weight** kg
Add-on hydraulic with 4-fold control block	<b>02-9000</b>	approx 10	68	60	800	643	1020	350

\*\* excluding oil

## Control unit

The control unit is the central point from which all movement sequences of the rerailing process (lifting, lowering, pushing and pulling) are controlled and monitored. Up to four or six hydraulic consumers can be connected to the control unit. This number can be increased by using distribution valves (p. 24). The hydraulic consumers are each connected via a pair of hoses (p. 24). The control valve and all other hydraulic components are protected by a fixed hood (with integrated storage compartment).



03-1004

### Control units

	Order no.:	Connections hydraulic consumers	Length mm	Width mm	Height mm	Weight kg
Control unit with 4-fold control block	<b>03-1004</b>	4	806	706	965	47
Control unit with 6-fold control block	<b>03-1006</b>	6	1046	706	965	55

# 4 Hydraulic lifting jack

These lifting jacks made of high-strength light-metal alloy generally operate with the hydraulic re-pressure system at 30 MPa. A releasable return valve with pressure protection at both ends is mounted on the fixed integrated base, thus ensuring optimum stability. This prevents the load dropping in the event of hose severance, for example, and optimally protects the lifting jacks against overload and pressure multiplication. Safe

and jerk-free operation is guaranteed even under full load. By using piston support pieces and cylinder support rings (support set) it is possible to extend the stroke of all low-height lifting jacks step by step. Lifting jacks from all series have been coordinated with each other as regards lifting capacities and closed heights and stroke heights such that they can be used together without any problems. The high type of jack can continue with the work as soon as the low type

has reached its stroke limits. Series 600, 1000 and 1200 flat-type jacks are available for dealing with extremely low lifting points. With these jacks the stroke can also be extended by means of support sets.

## Lifting jack series 400



04-1042

04-1041 und 04-1044

04-2042

Lifting jack series 400					
Type		EH 400-250	TH 400/200-250	EH 400-470	TH 400/200-470
<b>Order no.:</b>		<b>04-1041</b>	<b>04-1042</b>	<b>04-2041</b>	<b>04-2042</b>
Closed height	mm	250	250	470	470
Number of pistons		1	2	1	2
Total stroke	mm	122	230	320	635
Stroke I	mm	122	122	320	320
Stroke II	mm	-	108	-	315
Effective force*	kN	495	495	495	495
Effective force II*	kN	-	191	-	191
Oil capacity	l	2,0	2,7	5,3	7,3
Bottom flange dia.	mm	295	295	295	295
Weight	kg	30	31	45	48
<b>Order no. support set</b>		<b>04-1044</b>	<b>04-1044</b>	-	-
Stroke extension	mm	4 x 90 = 360	4 x 90 = 360	-	-

\* possible deviation from forces specified: ±5 %

# Lifting jack series 600



04-1065



04-1061



04-1062



04-2061



04-2062

Lifting jack series 600						
Type		EH 600-130	EH 600-250	TH 600/300-250	EH 600-450	TH 600/300-450
<b>Order no.:</b>		<b>04-1065</b>	<b>04-1061</b>	<b>04-1062</b>	<b>04-2061</b>	<b>04-2062</b>
Closed height	mm	130	250	250	450	450
Number of pistons		1	1	2	1	2
Total stroke	mm	45	110	215	278	566
Stroke I	mm	45	110	110	278	278
Stroke II	mm	-	-	105	-	288
Effective force I*	kN	581	681	681	681	681
Effective force II*	kN	-	-	285	-	285
Oil capacity	l	0,9	2,5	3,5	6,3	9,1
Bottom flange dia.	mm	295	295	295	295	295
Weight	kg	22	37	38	54	58
<b>Order no. support set</b>		<b>04-1066</b>	<b>04-1064</b>	<b>04-1064</b>	-	-
Stroke extension	mm	4 x 25 = 100	4 x 80 = 320	4 x 80 = 320	-	-

Three-piston jacks from this series can also be supplied on request

\* Possible deviation from forces specified: ±5 %

# 4 Lifting jack series 900

Lifting jack series 900					
Type		EH 900-250	TH 900/450-250	EH 900-425	TH 900/450-425
<b>Order no.:</b>		<b>04-1091</b>	<b>04-1092</b>	<b>04-2091</b>	<b>04-2092</b>
Closed height	mm	250	250	425	425
Number of pistons		1	2	1	2
Total stroke	mm	97	185	250	500
Stroke I	mm	97	97	250	250
Stroke II	mm	-	88	-	250
Stroke III	mm	-	-	-	-
Effective force I*	kN	896	896	896	896
Effective force II*	kN	-	429	-	429
Effective force III*	kN	-	-	-	-
Oil capacity	l	2,9	4,2	7,5	11,0
Bottom flange dia.	mm	330	330	330	330
Weight	kg	48	49	63	66
<b>Order no. support set</b>		<b>04-1094</b>	<b>04-1094</b>	-	-
Stroke extension	mm	4 x 75 = 300	4 x 75 = 300	-	-

Three-piston jacks from the 900 series can also be supplied on request.  
 \* Possible deviation from forces specified: ±5 %



04-2092



# Lifting jack series 1000



04-0103



04-0103 and 04-0104

Lifting jack series 1000		
Type		TH 1000/500/200-170
<b>Order no.:</b>		<b>04-0103</b>
Closed height	mm	170
Number of pistons		3
Total stroke	mm	198
Stroke I	mm	76
Stroke II	mm	61
Stroke III	mm	61
Effective force I*	kN	1039
Effective force II*	kN	495
Effective force III*	kN	190
Oil capacity	l	4,1
Bottom flange dia.	mm	344
Weight	kg	41
<b>Order no. support set</b>		<b>04-0104</b>
Stroke extension	mm	4 x 55 = 220
		<b>04-0106</b>
		06 x 55 = 330

\* Possible deviation from forces specified: ±5 %

# Lifting jack series 1200



04-1125



04-1122



04-2122



04-2123

Lifting jack series 1200						
Type		EH 1200-140	EH 1200-250	TH 1200/600-250	EH 1200-420	TH 1200/600-420
<b>Order no.:</b>		<b>04-1125</b>	<b>04-1121</b>	<b>04-1122</b>	<b>04-2121</b>	<b>04-2122</b>
Closed height	mm	140	250	250	420	420
Number of pistons		1	1	2	1	2
Total stroke	mm	41	90	180	243	488
Stroke I	mm	41	90	90	243	243
Stroke II	mm	-	-	90	-	245
Effective force I*	kN	1140	1140	1140	1140	1140
Effective force II*	kN	-	-	581	-	581
Oil capacity	l	1,6	3,4	5,1	9,2	14,0
Bottom flange dia.	mm	380	370	370	370	370
Weight	kg	45	56	57	75	79
<b>Order no. support set</b>		<b>04-1126</b>	<b>04-1124</b>	<b>04-1124</b>	-	-
Stroke extension	mm	4 x 21 = 84	4 x 65 = 260	4 x 65 = 260	-	-

\* Three-piston jacks from this series can also be supplied on request

\* Possible deviation from forces specified:  $\pm 5\%$

# 4 Hydraulic lifting jacks (other jacks)

## Single-piston jacks EH 350 and EH 200

These lifting jacks can be used in combination with different add-on parts for various tasks:

1. By using the claw (order no. 04-0041 -P) long strokes are possible from low lifting points.
2. When fitted with the pressure piece (supplied as standard accessory) it is used whenever long strokes are required from high lifting points.
3. When used with the head piece (06-2352), rounded head piece (06-2353) and also rocker bearing support (06-3351) the jack 04-0041 forms an important part of the uprighting device. (see equipment group 6, p. 20)



04-0041-P



04-0041



04-0021-1

## Tilting jack

The tilting jack is used for lifting two-axle vehicles and putting them back on the track.

During this operation the tilting jack performs the lifting and lateral displacement movements simultaneously while the associated hooked wheel stop prevents the wheel coming off the rail.



04-0021-2



04-0010

## Internal lifting jack EH 100

This single piston jack is intended for use with interior lifting points in trams and subway carriages.

The internal lifting jack has an unlockable non-return valve with a pressure safety device at each end. The downward travelling piston is equipped with a rocker support which

can compensate for inclined positions of the jack. The form of the jack can be adapted to different lifting devices or to adapter types, threaded connections and attachment functions. The bayonet adapter can be positioned as desired, such as centrally or at the top.

Other lifting jacks							
Type	EH 350-1030	EH 350-1030	EH 200-658	EH 200-597	EH 100	EH 200	
	Large claw jack	Without claw	Small claw jack	Tilting jack	Internal jack	Internal jack	
<b>Order no.:</b>	<b>04-0041P</b>	<b>04-0041</b>	<b>04-0021-1</b>	<b>04-0021-2</b>	<b>04-0010</b>	<b>04-0020</b>	
Closed height	mm	1030	1030	658	597	***	***
Number of pistons		1	1	1	1	1	1
Total stroke	mm	660	825	416	400	***	***
Effective force I*	kN	339	339	190	199	115	212
Oil capacity	l	7,5	9,3	2,6	2,7	***	***
Weight	kg	125	70	41	57/16	***	***
Claw height	mm	105	-	100**	-	-	-

Internal jacks with even greater effective force can be supplied

\* Possible deviation from forces specified:  $\pm 5\%$

\*\* including rocker bearing support

\*\*\* Depending on the vehicle type

# 5 Equipment for lateral displacement

## Lateral displacement

Lateral displacement equipment allows the lifted derailed vehicle to be pulled and pushed until it is precisely aligned with the track and transported. The lateral displacement components described below should be selected in accordance with requirements.



Overall height 95 mm



Overall height 180 mm

## Rerailing bridges

The bridges are hollow extruded sections of high-strength light-metal alloy. All bridges can be coupled together and are equipped with four retractable handles. The upper side has drilled holes to accommodate the countersupport.

## Bridge coupling

The bridge coupling is used for joining together two rerailing bridges.



05-2000

Rerailing bridges and bridge couplings							
Type	Order no.:	Height mm	Length mm	Width mm	Weight kg	Load-bearing capacity* kN	Load-bearing capacity** kN
AB 4500-180	05-2450	180	4500	280	175	600	1200
AB 3300-180	05-2330	180	3300	280	128	600	1200
AB 2250-180	05-2225	180	2250	280	88	600	1200
AB 1200-180	05-2120	180	1200	280	47	600	1200
BK 180	05-2000	-	-	-	37,5	-	-
AB 4500-95	05-1450	95	4500	280	125	100	600
AB 3300-95	05-1330	95	3300	280	92	100	600
AB 2250-95	05-1225	95	2250	280	63	100	600
AB 1200-95	05-1120	95	1200	280	34	100	600
BK 95	05-1000	-	-	-	22	-	-

\*Average loading over a free span 1500 mm

\*\* Loading with a rerailing bridge wedged over its full area



## Roller carriage

The roller carriages are used for traversing the load on the rerailing bridge. Well dimensioned rollers with maintenance-free

bearings permit easy lateral transport with little expenditure of energy.

Roller carriages						
Type	Roller carriage designation	Order no.:	Max. load kN	Height without plate mm	Height with plate mm	Weight kg
RW 150	150 kN, without plate	<b>05-1015</b>	150	66	-	18
RWP 150	150 kN, with plate	<b>05-1016</b>	150	66	101	30
RW 600	600 kN, without plate	<b>05-2061</b>	600	108	-	58
RWP 600	600 kN, with plate	<b>05-2062</b>	600	108	140	82
RW 1200	1200 kN, without plate	<b>05-2121</b>	1200	108	-	70
RWP 1200	1200 kN, with plate	<b>05-2122</b>	1200	108	140	94

### 150 kN

Provided with two pockets for accommodating displacing jacks, distance bars or stopping devices. Due to its extremely low overall height this roller carriage is preferably used with trams or subway carriages.



05-1015

### 150 kN with plate

With rotating and sliding plate to compensate for radial forces occurring when loads lifted at one end are being moved.



05-1016

### 600 kN/1200 kN

Provided with two pockets for accommodating displacing jacks, distance bars, stopping devices.



05-2061 und 05-2121

### 600 kN/1200 kN with plate

With rotating and sliding plate to compensate for radial forces occurring when loads lifted at one end are being moved.



05-2062 und 05-2122

# 5 Equipment for lateral displacement

## Displacing jack

The displacing jack has a pushing force of 120 kN and a pulling force of 60 kN. Both pushing and pulling is therefore possible during the lateral displacement movement. This is a special advantage of the re-pressure system. The displacing cylinder is also a component of the axle pusher unit. (see p. 23)



05-0011

Displacing jack								
Type	Order no.:	Closed length mm	Number of pistons	Stroke mm	Effective pushing force* kN	Effective pulling force* kN	Oil capacity l	Weight kg
EH 120/60-575	05-0011	575	1	350	129	57	1,5	16,5

\* Possible deviation from forces specified:  $\pm 5\%$



Type I - 05-5001

### Type I distance bar

For coupling two roller carriages, length continuously adjustable from 1023 mm to 1904 mm.



Type II - 05-5002

### Type II distance bar

For coupling two roller carriages, length continuously adjustable from 1046 mm to 2645 mm.

Distance bars				
Type	Order no.:	Range of adjustment (mm)		Weight kg
		min	max	
Type I	05-5001	1023	1904	20
Type II	05-5002	1046	2645	24
Type III	05-5003	780	1967	18,5

Accessories for lateral displacement		
Order no.:	Designation	Weight kg
05-4001	Single counter support	8
05-4001-1	Counter support with bolt lock	21
05-4002	Twin counter support	16
05-3000	Twin head socket	9
05-6000	Stopping device and single counter support	12

### Twin counter support and twin head socket

The twin counter support in combination with the twin head socket is always used when high lateral pushing forces are needed. The twin head socket is to be positioned in a pocket of the roller carriage and should accommodate two parallel operating displacing jacks.

### Single counter support

To be inserted into the bores of the rerailing bridge. It is used for holding the displacing jack.

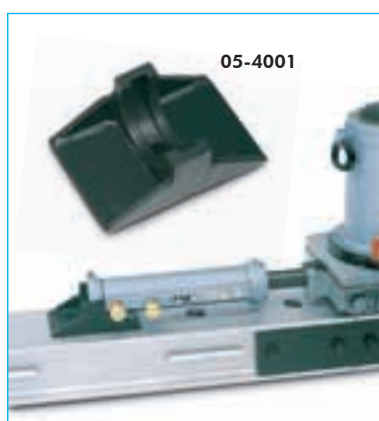

Single counter support application



Twin counter support with twin head socket application

### Counter support with bolt lock

This is also used for holding the displacing jack. The support is fixed to the rerailing bridge using a spring-loaded bolt which automatically locks into the next hole in the rerailing bridge during hydraulic operation of the displacing jack. It can be unlocked by means of a handle on the counter support. This enables the displacing jack to be hydraulically traversed with automatic locking so that the displacing stroke can be repeated as often as necessary.



05-4001-1

### Stopping device for roller carriages

Use in combination with a counter support. It is used for locking the roller carriages when relocating the displacing jacks (especially in the case of superelevations).



05-6000

# 6 Equipment for uprighting

This equipment is used for uprighting overturned vehicles. It basically consists of the single-piston jacks 350 kN (order no. 04-0041; see p. 14), rope lifting belts, head pieces and rocker bearing supports.



## Head piece and rounded head piece

These are used instead of the jack thrust pad for holding the rope lifting belt loop.



06-2352



06-2353

## Rocker bearing support

It is used for compensating for the angular movement of the lifting jack and for safely transmitting the counterforce to the ground.



06-3351

Uprighting unit							
Designation	Order no.:	Lenght of belts mm	Number of loops	Load bearing capacity kN	Lenght of attachment rope m	Lenght of retaining rope m	Weight kg
Lifting belt, complete	<b>06-1350</b>	3025	6	350	4	6	33
Head piece for EH 350-1030 (04-0041)	<b>06-2352</b>	-	-	-	-	-	9
Rounded head piece for EH 350-1030 (04-0041)	<b>06-2353</b>	-	-	-	-	-	5
Rocker bearing support EH 350-1030 (04-0041)	<b>06-3351</b>	-	-	-	-	-	16,5

### Lifting cable ladder carrying capacity 350 kN

With an overturned vehicle this substitutes for the missing fixing points for the lifting jacks and consists of:

- Lifting cable ladder
- Connecting bolts
- Fastening rope
- Retaining rope

06-1350



### Haulage device

Used either for moving rail vehicles with locked axles or for pulling apart vehicles which are locked together due to an accident. The device is attached to the track by means of rail blocks, wedges and retaining ropes. It can also be used for uprighting overturned vehicles.

Accessories:

2 rail blocks

4 wedges

swivels, fastening, pulling and retaining ropes



#### Haulage device

Order no.:	Lenght of pulling rope	Lenght of fasten rope	Lenght of retaining rope	Tractive force	Weight (without accessories)	Weight (with accessories)
	m	m	m	kN	kg	kg
<b>07-1250</b>	10	10	10	250	107	250

\* Possible deviation from forces specified:  $\pm 10\%$

## 8 Auxiliary Tow-Truck

Auxiliary tow-trucks are used for moving vehicles in which important parts of the travelling gear are defective.

The individual components of the auxiliary tow-truck can be assembled on the site. The damaged vehicle can then be hauled to the nearest workshop for repair. Auxiliary tow trucks are basically produced as single items which are then adapted to the requirements of the vehicle to be hauled, taking into account any obstruction there may be in the track area.



08-1160 Light series



08-2220 Heavy series

Auxiliary tow-trucks				
Order no.:	Load-bearing capacity kN	Max. haulage speed km/h	Total weight kg	Construction type
08-1160	160	25	approx. 110 - 170	Light series
08-1200	200	40	approx. 140 - 210	Light series
08-2220	220	40	approx. 480	Heavy series
08-2300	300	40	approx. 600	Heavy series
08-2380	380	40	approx. 740	Heavy series
08-2700	700	40	approx. 1.250	Heavy series

# Accessories

## Axle pusher unit

To be used in combination with the displacing jack to move a wheel resting on the rail by its flange or as an auxiliary device for the lateral displacement of a lifted vehicle.

This device often makes a complete lifting operation unnecessary. It consists of two retaining ropes with hooks and bolts together with a crossbeam of light-metal alloy.

The displacing cylinder\* is not included with this order number.

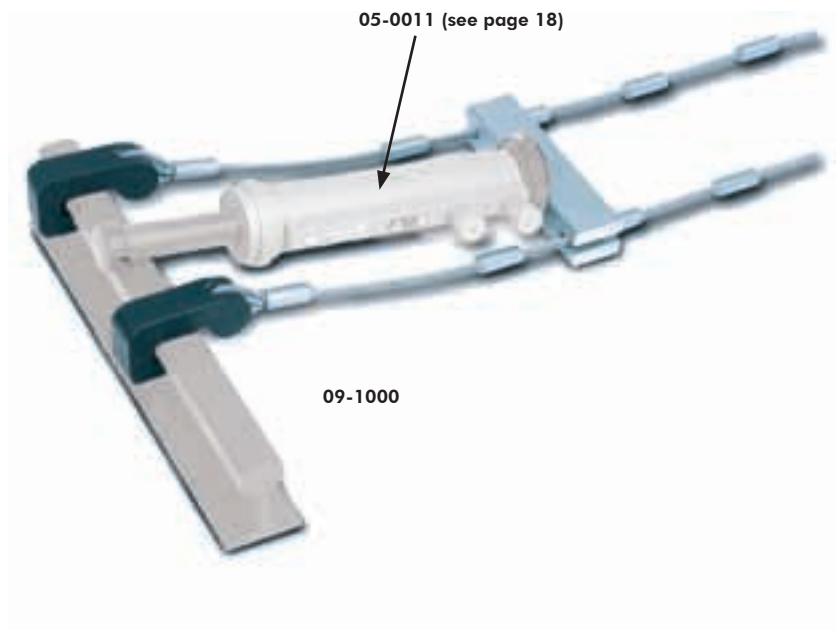

Axle pusher units			
Order no.:	Rope length mm	Distance between rope mm	Weight kg
09-1000	1500	300	22,5
09-1001	2440	300	25,0

\*To be ordered separately (see p. 18)

# 9 Accessories



09-2005 / 09-2010

## High-pressure hoses

The high-pressure hoses bundled in pairs serve to connect the control unit, the pump unit and the hydraulic components. The screw couplings are provided with integrated stop valves to prevent any oil leakage even when the hoses are uncoupled. The screw couplings can be coupled and uncoupled manually even under residual pressure.

## Hose couplings

Hose couplings are used for extending the high-pressure hose lines. Hose coupling 09-2101 is fitted with a stop valve at each end. This means that two hoses can be coupled together without loss of oil.



09-2101

09-2100

High-pressure hoses (in pairs)						
Order no.:	Standard length m	Nominal diameter mm	Bending radius mm	Operating pressure MPa	Design pressure MPa	Weight kg
09-2005	5	10	100	31,5	75,0	5
09-2010	10	10	100	31,5	75,0	9

Hose couplings			
Order no.:	Designation	Thread	Weight kg
09-2100	Hose coupling (single)	Rd32x3	0,3
09-2101	Hose coupling (with stop valve)	Rd32x3	1,0

## Distribution valves

For connecting an additional hydraulic component.

Distribution valves with regulators are able to compensate for any loss of pressure in the lines which means that connected hydraulic components can be extended and withdrawn evenly.



09-2200



09-2201

Distributions valves			
Order no.:	Designation	Connections	Weight kg
09-2200	Distribution valve (simple)	1 pair (red/blue)-input 2 pairs (red/blue)-output	7
09-2201	Distribution valve (with regulator)	1 pair (red/blue)-input 2 pairs (red/blue)-output	8



## Bogie suspensions

They are used with bogies which are not firmly attached to the vehicle.

- **Type A** is hooked onto the vehicle frame.
- **Type B** is clamped additionally to the vehicle frame during the lifting process.



Type A – 09-3001



Type B – 09-3002

### Bogie suspensions

Order no.:	Designation	Weight kg	Chain Weight kg
09-3001	Type A (simple)	3,5	13
09-3002	Type B (with spring hook)	14	13

## Carrier vehicles

These combined road/rail vehicles can transport rerailing equipment as well as all other required equipment to the site of the accident by the quickest route.

The add-on hydraulic unit specially developed by Hegenscheidt-MFD is attached to the front of the vehicle and replaces the pump unit and control panel which would otherwise be required.

(see p. 9)



The space saved in this way on the vehicle floor can be used for stowing other equipment.

The Hegenscheidt-MFD system provides an optimum load distribution and equipment stowage in the vehicle.

The configuration of the carrier vehicle can be customised by Hegenscheidt-MFD to suit special requirements.



# 11 Rescue equipment and accessories

Supplementing the rerailing system Hegenscheidt-MFD also offers rescue equipment.



Hydraulic pump*				
Order no.:	Designation	Operating pressure MPa	Dimension L x W x H (mm)	Weight kg
11-3005	Pump type TPU 35 PF	72	410 x 325 x 375	25



Cutters*						
Order no.:	Designation	max. cutting force (recess) kN	Max. cutting force (centre of opening) kN	max. jaw width	Operating pressure MPa	Weight kg
11-3010	Cutter Type CU 4020	341	188	152	72	10,6



Spreaders*							
Order no.:	Designation	Max. spread force kN	Max. tensile force kN	Max. spread width	Max. traction distance	Operating pressure MPa	Weight kg
11-3020	Spreader Type SP 4240	157	83,4	686	450	72	18,1

Accessories	
Order no.:	Designation
11-3021	Pull chain with hook length 4500 mm
11-3024	Connection
11-3100	Extensionhose, 10 m

\* Additional equipment on request

# Air bags and accessories

In extremely difficult rerailing situations (very low lifting points, derailments close to tunnel walls, and so on) the use of pneumatic air bags has proved itself.

The drive unit has a mobile compressor equipped with its own prime mover which is available either as a combustion engine or as an electric motor.

It should be particularly emphasised that this design means virtually unlimited compressed air.



12-1010-1

Air bags*						
Order no.:	Designation	max. lift force (at 0,8 MPa) kN	max. lift height mm	Dimensions mm	Bag thickness mm	Weight kg
12-4290	Air bag HLB 29	300	348	611 x 611	25	9,8
12-4320	Air bag HLB 32	320	380	658 x 658	25	13
12-4400	Air bag HLB 40	400	405	714 x 714	25	15,1
12-4670	Air bag HLB 67	670	520	908 x 908	25	23,5

Compressors*					
Order no.:	Designation	Operating pressure MPa	Air volume m <sup>3</sup> /min	Dimensions L x W x H (mm)	Operating weight kg
12-1010-1	Compressor with petrol engine	0,7	1,4	960 x 700 x 630	160
12-1010-2	Compressor with electric motor	0,8	0,37	1.190 x 500 x 840	80

Accessories*	
Order no.:	Designation
12-1002	Dual control device
12-1100B	Air hose (blue), 10 m
12-1100R	Air hose (red), 10 m
12-1100Y	Air hose (yellow), 10 m

\* Additional equipment on request



12-1002

12-1100R

# Index of order numbers

## Hydraulic drive systems

2

Order no.:	Designation	Weight (kg)	Type	Page
<b>with combustion engine</b>				
02-6000	Pump unit (large) with diesel engine	108	PA-D	6
02-4000	Pump unit (large) with four-stroke engine	93	PA-4	6
02-4020	Pump unit (small) with four-stroke engine	48	PA-4K	6
<b>with combustion engine and control unit</b>				
02-4320	Pump unit (small) with four-stroke engine and 3-way control block	77	PA-4 / 3K	6
<b>with electric motor</b>				
02-8000	Pump unit (large) with electric motor	100	PA-E	7
02-8020	Pump unit (small) with electric motor	55	PA-ESK	7
<b>with electric motor and control unit</b>				
02-8400	Pump unit (large) with electric motor and 4-way control block	132	PA-ES	7
02-8220	Pump unit (small) with electric motor and 2-way control block	71	PA-ESK2	7
02-8320	Pump unit (small) with electric motor and 3-way control block	74	PA-ESK3	7
02-8420	Pump unit (small) with electric motor and 4-way control block	76	PA-ESK4	7
<b>Hand pumps</b>				
02-1220	Hand pump (small) with 2 connections	68	HP 2/20	8
02-1230	Hand pump (large) with 2 connections	75	HP 2/30	8
02-1320	Hand pump (small) with 3 connections	70	HP 3/20	8
02-1330	Hand pump (large) with 3 connections	77	HP 3/30	8
02-2120	Emergency hand pump	26	NHP 1/20	8
<b>for carrier vehicle</b>				
02-9000	Add-on hydraulic unit with 4-way control block	350	ABH	9

## Control units

3

Order no.:	Designation	Weight (kg)	Type	Page
03-1004	Control unit with 4-way control block	47	SP4	9
03-1006	Control unit with 6-way control block	55	SP6	9

## Hydraulic lifting jacks

4

Order no.:	Designation	Weight (kg)	Type	Page
<b>Lifting jack series 400</b>				
04-1041	Single-piston jack 400 kN, height 250 mm, stroke 122 mm	30	EH 400-250	10
04-1042	Telescopic jack 400/200 kN, height 250 mm, stroke 230 mm	31	TH 400/200-250	10
04-2041	Single-piston jack 400 kN, height 470 mm, stroke 320 mm	45	EH 400-470	10
04-2042	Telescopic jack 400/200 kN, height 470 mm, stroke 635 mm	48	TH 400/200-470	10
04-1044	Support set for 04-1041 and 04-1042	25	A 400-250	10
<b>Lifting jack series 600</b>				
04-1065	Flat-type jack 600 kN, height 130 mm, stroke 45 mm	22	EH 600-130	11
04-1061	Single-piston jack 600 kN, height 250 mm, stroke 110 mm	37	EH 600-250	11
04-1062	Telescopic jack 600/300 kN, height 250 mm, stroke 215 mm	38	TH 600/300-250	11
04-2061	Single-piston jack 600 kN, height 450 mm, stroke 278 mm	54	EH 600-450	11
04-2062	Telescopic jack 600/300 kN, height 450 mm, stroke 566 mm	58	TH 600/300-450	11

Order no.:	Designation	Weight (kg)	Type	Page
<b>Lifting jack series 600</b>				
04-1066	Support set for 04-1065	10	A 600-130	11
04-1064	Support set for 04-1061 and 04-1062	29	A 600-250	11
<b>Lifting jack series 900</b>				
04-1091	Single-piston jack 900 kN, height 250 mm, stroke 97 mm	48	EH 900-250	12
04-1092	Telescopic jack 900/450 kN, height 250 mm, stroke 185 mm	49	TH 900/450-250	12
04-2091	Single-piston jack 900 kN, height 425 mm, stroke 250 mm	63	EH 900-425	12
04-2092	Telescopic jack 900/450 kN, height 425 mm, stroke 500 mm	66	TH 900/450-425	12
04-1094	Support set for 04-1091 and 04-1092	33	A 900-250	12
<b>Lifting jack series 1000</b>				
04-0103	Telescopic jack 1000/500/200 kN, height 170 mm, stroke 198 mm	41	TH 1000/500/200-170	12
04-0104	Support set for 04-0103 (4-piece)	13	A4 1000-170	12
04-0106	Support set for 04-0103 (6-piece)	15	A6 1000-170	12
<b>Lifting jack series 1200</b>				
04-1125	Flat-type jack 1200 kN, height 140 mm, stroke 41 mm	45	EH 1200-140	13
04-1121	Single-piston jack 1200 kN, height 250 mm, stroke 90 mm	56	EH 1200-250	13
04-1122	Telescopic jack 1200/600 kN, height 250 mm, stroke 180 mm	57	TH 1200/600-250	13
04-2121	Single-piston jack 1200 kN, height 420 mm, stroke 243 mm	75	EH 1200-420	13
04-2122	Telescopic jack 1200/600 kN, height 420 mm, stroke 488 mm	79	TH 1200/600-420	13
04-1126	Support set for 04-1125	13	A 1200-140	13
04-1124	Support set for 04-1121 and 04-1122	41	A 1200-250	13
<b>Other lifting jacks</b>				
04-0041	Single-piston jack 350 kN, height 1030 mm, stroke 825 mm	70	EH 350-1030	15
04-0041P	Claw jack (large) 350 kN, height 1030 mm, stroke 660 mm	125	PH 350-1030	15
04-0021-1	Claw jack (small) 200 kN, height 658 mm, complete with rocker bearing support	41	PH 200-658	15
04-0021-2	Tilting jack 200 kN, height 597 mm, complete with hooked wheel stop	57 / 16	KH 200-597	15
04-0010	Internal jack 100 kN	-	EH 100	15
04-0020	Internal jack 200 kN	-	IH 200	15

## Equipment for lateral displacement

Order no.:	Designation	Weight (kg)	Type	Page
<b>Rerailing bridges</b>				
05-2450	Rerailing bridge 4500 mm long, 180 mm high	175	AB 4500-180	16
05-2330	Rerailing bridge 3300 mm long, 180 mm high	128	AB 3300-180	16
05-2225	Rerailing bridge 2250 mm long, 180 mm high	88	AB 2250-180	16
05-2120	Rerailing bridge 1200 mm long, 180 mm high	47	AB 1200-180	16
05-1450	Rerailing bridge 4500 mm long, 95 mm high	125	AB 4500-95	16
05-1330	Rerailing bridge 3300 mm long, 95 mm high	92	AB 3300-95	16
05-1225	Rerailing bridge 2250 mm long, 95 mm high	63	AB 2250-95	16
05-1120	Rerailing bridge 1200 mm long, 95 mm high	34	AB 1200-95	16

# Index of order numbers

## Equipment for lateral displacement

5

Order no.:	Designation	Weight (kg)	Type	Page
<b>Bridge couplings</b>				
<b>05-2000</b>	Set of bridge couplings (high)	37,5	BK 180	16
<b>05-1000</b>	Set of bridge couplings (low)	22	BK 95	16
<b>Roller carriages</b>				
<b>05-1015</b>	Roller carriage 150 kN without plate	18	RW 150	17
<b>05-1016</b>	Roller carriage 150 kN with plate	18 / 12	RWP 150	17
<b>05-2061</b>	Roller carriage 600 kN without plate	58	RW 600	17
<b>05-2062</b>	Roller carriage 600 kN with plate	58 / 24	RWP 600	17
<b>05-2121</b>	Roller carriage 1200 kN without plate	70	RW 1200	17
<b>05-2122</b>	Roller carriage 1200 kN with plate	70 / 24	RWP 1200	17
<b>Displacing jack</b>				
<b>05-0011</b>	Displacing jack 120/60 kN, length 575 mm	16,5	EH 120/60-575	18
<b>Distance bars</b>				
<b>05-5001</b>	Distance bar 1023 - 1904 mm (Type I)	20	AH-I	18
<b>05-5002</b>	Distance bar 1046 - 2645 mm (Type II)	24	AH-II	18
<b>05-5003</b>	Distance bar 780 - 1967 mm (Type III)	18,5	AH-III	18
<b>Accessories for lateral displacement</b>				
<b>05-4001</b>	Single counter support	8	G	19
<b>05-4001-1</b>	Counter support with bolt lock	21	GB	19
<b>05-4002</b>	Twin counter support	16	DG	19
<b>05-3000</b>	Twin head socket	9	DA	19
<b>05-6000</b>	Stopping device for roller carriage, complete with single counter support	12	HV	19

## Equipment for uprighting

6

Order no.:	Designation	Weight (kg)	Type	Page
<b>06-1350</b>	Lifting cable ladder	33	SL	20
<b>06-2352</b>	Head piece for single-piston jack 350 kN	9	KSL	20
<b>06-2353</b>	Rounded head piece for single-piston jack 350 kN	5	KRSL	20
<b>06-3351</b>	Rocker bearing support for single-piston jack 350 kN	16,5	GP	20

## Haulage devices

7

Order no.:	Designation	Weight (kg)	Type	Page
<b>07-1250</b>	Haulage device 250 kN, complete with accessories	107 / 143	ZE 250	21

## Auxiliary trucks

8

Order no.:	Designation	Weight (kg)	Type	Page
<b>08-1160</b>	Auxiliary tow-truck 160 kN, (customer adaptation)	approx. 110 - 170	HAW 160	22
<b>08-1200</b>	Auxiliary tow-truck 200 kN, (customer adaptation)	approx. 140 - 210	HAW 200	22
<b>08-2220</b>	Auxiliary tow-truck 220 kN (customer adaptation)	approx. 480	HAW 220	22
<b>08-2300</b>	Auxiliary tow-truck 300 kN (customer adaptation)	approx. 600	HAW 300	22
<b>08-2380</b>	Auxiliary tow-truck 380 kN (customer adaptation)	approx. 740	HAW 380	22
<b>08-2700</b>	Auxiliary tow-truck 380 kN (customer adaptation)	approx. 1.250	HAW 700	22

## Accessories

Order no.:	Designation	Weight (kg)	Type	Page
<b>Axle pushers</b>				
09-1000	Axle pusher	22,5	AE	23
09-1001	Axle pusher, long rope	25,0	AE-S	23
<b>High-pressure hoses</b>				
09-2005	Pair of high-pressure hoses, 5m long	5	HS-5	24
09-2010	Pair of high-pressure hoses, 10m long	9	HS-10	24
<b>Hose couplings</b>				
09-2100	Hose coupling, simple	0,3	SV	24
09-2101	Hose coupling with stop valves	1,0	SV-S	24
<b>Distribution valves</b>				
09-2200	Distributor valve	7	VST	24
09-2201	Distributor valve with regulators	8	VST-D	24
<b>Bogie suspensions</b>				
09-3001	Bogie suspension Type A (simple) with chain	3,5 / 13	DA-A	25
09-3002	Bogie suspension Type B (with spring hook) with chain	14 / 13	DA-B	25

## Rescue devices

Order no.:	Designation	Weight (kg)	Type	Page
11-3005	Pump for rescue gear	25	PA-R	26
11-3010	Hydraulic cutters	10,6	CU 4020	26
11-3020	Hydraulic spreaders	18,1	SP 4240	26
<b>Accessories</b>				
11-3021	Pull chain with hook, 4500 mm long, for spreaders			26
11-3024	Connection for spreaders			26
11-3100	Set of extension hoses, 10 m			26

## Air bags and accessories

Order no.:	Designation	Weight (kg)	Type	Page
<b>Air bags</b>				
12-4290	Air bag 290 kN	9,8	HLB 29	27
12-4320	Air bag 320 kN	13	HLB 32	27
12-4400	Air bag 400 kN	15,1	HLB 40	27
12-4670	Air bag 670 kN	23,5	HLB 67	27
<b>Compressor</b>				
12-1010-1	Compressor with petrol engine	160	C 14	27
12-1010-2	Compressor with electric motor	80	450/90	27
<b>Accessories</b>				
12-1002	Dual control device		HDC 10 U	27
12-1100B	Air hose (blue), 10 m		AH 10 BU	27
12-1100R	Air hose (red), 10 m		AH 10 RU	27
12-1100Y	Air hose (yellow), 10 m		AH 10 YU	27

THE TECHNOLOGY PROVIDER



THE NSH GROUP

NILES SIMMONS HEGENSCHIEDT



...technology in motion

Hegenscheidt  MFD



IKEMA spol. s.r.o.  
Tabaková 2  
900 27 Bernolákovo  
SLOVAKIA

tel.: +421 (2) 4599 4876  
e-mail: [ikema@ikema.sk](mailto:ikema@ikema.sk)  
[www.ikema.sk](http://www.ikema.sk)