



## simalube štandardné mazivá a príslušenstvo

MAZACÍ TUK	NLGI	Zahusťovadlo	Teplotný rozsah	Viskozita pri 40 °C	Valvé ložiská	Kĺzné ložiská	Lineárne vedenia	Prevodovky / ozubené lyže	Vrelná	Hriadeľové tesnenia	Rezače
<b>SL01</b> Viacúčelové mazivo	2	Lítium-Calcium	-30 °C až 120 °C	100	+	+	•	•	+	+	-
<b>SL02</b> Viacúčelové mazivo s MoS <sub>2</sub>	2	Lítium	-25 °C až 130 °C	370	•	+	-	+	-	-	-
<b>SL04</b> Vysokoteplotné mazivo	2	Anorganické zahusťovadlo	-20 °C až 160 °C	500	+	•	-	•	•	-	-
<b>SL06</b> Vodeodolný tekutý tuk (EP)	0	Calcium-Lítium	-30 °C až 100 °C	75	+	+	+	+	•	-	-
<b>SL09</b> Biologicky odbúrateľné mazivo	2	Lítium-Calcium	-20 °C až 100 °C	100	+	+	•	•	-	-	-
<b>SL10</b> Mazivo pre potravinársky priemysel (NSF H1)	2	Aluminium-Komplex	-40 °C až 120 °C	330	+	+	•	+	•	-	-
<b>SL12</b> Tekuté mazivo pre potravinársky priemysel (NSF H1)	0	Aluminium-Komplex	-40 °C až 130 °C	350	+	+	+	+	•	-	-
<b>SL24</b> Mazací tuk pre široký rozsah teplôt (EP)	2	Lítium-Komplex	-30 °C až 140 °C	185	+	+	•	•	+	+	-
<b>SL25</b> Vysokorychlostné mazivo	2	Polyurea	-20 °C až 160 °C	110	+	•	-	•	•	-	-
<b>SL26</b> Vysokovýkonné mazivo (EP)	1,5	Calcium-Komplex	-20 °C až 150 °C	460	+	+	-	•	•	-	-

+ doporučené • možné - neodporúčané



Technické listy mazacích tukov a olejov su dostupné na stránke [www.simatec.com/en/simalube/overview/lubricants](http://www.simatec.com/en/simalube/overview/lubricants)



OLEJ	ISO-VG	Základný olej	Teplotný rozsah	Viskozita pri 40 °C	Valivé ložiská	Klzné ložiská	Lineárne vedenia	Prevodky/ ozubené tyče	Vretená	Hriadešové lesnenia	Režaze
<b>SL14</b> Refazový olej (EP)	68	Minerálny olej	-10 °C až 90 °C	68	-	•	•	-	-	-	+
<b>SL15</b> Vysokoteplotný refazový olej (EP)	-	Syntetický olej	-30 °C až 250 °C	250	-	•	•	-	-	-	+
<b>SL16</b> Strojový olej	68	Minerálny olej	-20 °C až 100 °C	68	-	•	•	-	-	-	+
<b>SL18</b> Olej pre potravinársky priemysel (NSF H1)	220	Syntetický olej	-15 °C až 150 °C	220	-	•	•	-	-	-	+
<b>SL19</b> Bio refazový olej	-	Repkový olej	-15 °C až 100 °C	60	-	•	•	-	-	-	+

+ doporučené    • možné    - nedoporučené

## Príklady použitia

Systém príslušenstva umožňuje použiť simalube kdekoľvek a vo všetkých pracovných polohách.

**Mazanie reťaze s bočným pripojením**

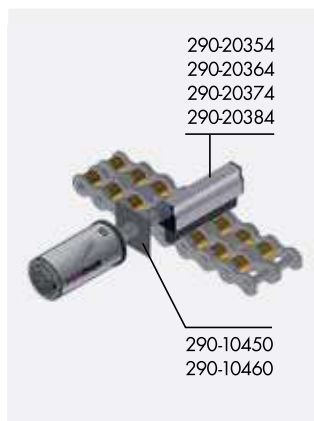

**Montážny držiak s upevňovacím uholníkom**



**Vodiace profily výťahov alebo mazanie oceľového lana**



**Mazanie reťaze pomocou štetca a 2 fixačných objímok**

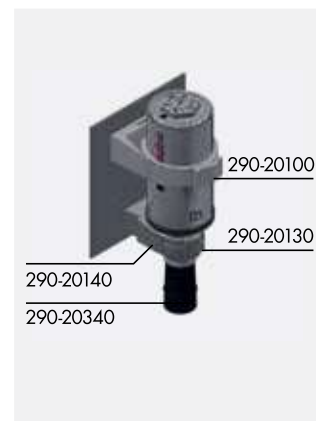

**Fixný montážny držiak so simalube ochranným krytom**



**Mazanie reťaze s fixačnou objímkou**



**Štetec s 90° pripojovacím adaptérom**



**Mazanie reťaze s univerzálnym prestaviteľným držiakom**

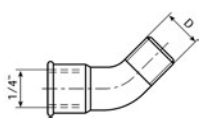
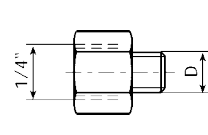
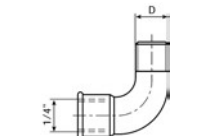
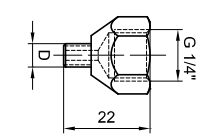
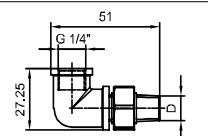
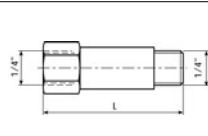
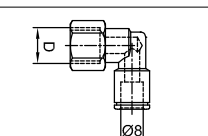
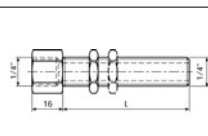
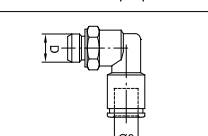
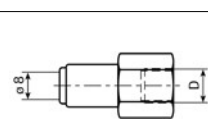
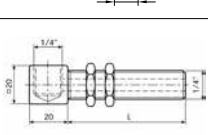
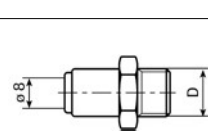
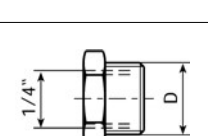
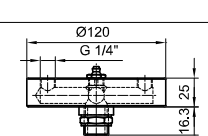
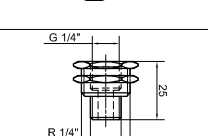
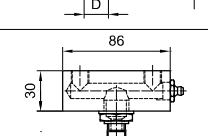

## Pripojenia

	<b>Kolienka 45°</b> <b>D</b> R 1/4 <b>Nr.</b> 290-10010		<b>Redukčná vsuvka</b> <b>D</b> G 1/8   G 1/4   M 6   M 8   M 8x1 <b>Nr.</b> 290-10200   290-10210   290-10220   290-10230   290-10240 <b>D</b> M 10   M 10x1   M 12   M 12x1,5   UNF 1/4 <b>Nr.</b> 290-10250   290-10260   290-10270   290-10280   290-11210
	<b>Kolienka 90°</b> <b>D</b> R 1/4 <b>Nr.</b> 290-10020		<b>Redukčný fitting v spevnenej verzii</b> Nerez <b>D</b> M6   UNF 1/4 <b>Nr.</b> 290-15000   290-15010
	<b>Kolienko 90° polohovateľné</b> <b>D</b> R 1/4 <b>Nr.</b> 290-10040		<b>Predĺžovací adaptér</b> <b>L</b> 10   35   50 [mm] <b>Nr.</b> 290-10210   290-10400   290-10410
	<b>Rýchlospojka uhlová</b> pre hadicu Ø 8 mm <b>D</b> G 1/4 <b>Nr.</b> 290-10030		<b>Závitové pripojenia na plech</b> veľkosť 25 mm vrátane 1 matice/veľkosť 60 mm vrátane 2 matíc <b>L</b> 25   60 [mm] <b>Nr.</b> 290-10450   290-10460
	<b>Rýchlospojka uhlová</b> pre hadicu Ø 8 mm <b>D</b> G 1/8   G 1/4 <b>Nr.</b> 290-10070   290-10080		<b>Rýchlospojka</b> pre hadicu Ø 8 mm <b>D</b> G 1/4 <b>Nr.</b> 290-10600
	<b>90° pripojenie so závitom</b> vrátane 2 matíc (len pre olej) <b>L</b> 70 [mm] <b>Nr.</b> 290-10050		<b>Rýchlospojka</b> pre hadicu Ø 8 mm <b>D</b> G 1/8   G 1/4   G 3/8 <b>Nr.</b> 290-10700   290-10710   290-10720
	<b>Pripojovacia vsuvka</b> <b>D</b> G 3/8   G 1/2 <b>Nr.</b> 290-10100   290-10110		<b>4 - bodový adaptér</b> <b>D</b> G 1/2   G 1/4 <b>Nr.</b> 290-41000   290-41010
	<b>Upevňovacia vsuvka G 1/2" - R 1/4"</b> <b>L</b> 25 [mm] <b>Nr.</b> 290-10150		<b>2 - bodový adaptér</b> <b>D</b> G 1/2   G 1/4 <b>Nr.</b> 290-41020   290-41030

## Príslušenstvo mazníc a iné

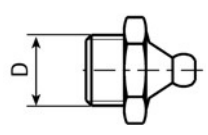
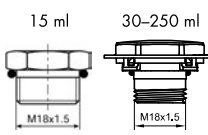
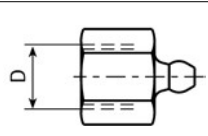
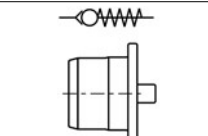
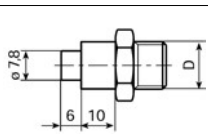
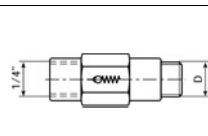
	<b>Plniaca vsuvka</b> na premazanie a naplnenie mazacích kanálikov <b>D</b> R 1/4 <b>Nr.</b> 290-30110		<b>Hnacia hlavica</b> pre znovunaplnenie <table border="1"> <tr> <td>15 ml</td> <td>30 ml</td> <td>60 ml</td> <td>125 ml</td> <td>250 ml</td> </tr> <tr> <td><b>Nr.</b> 220-50020</td> <td>220-50040</td> <td>220-50060</td> <td>220-50080</td> <td>220-50100</td> </tr> </table>	15 ml	30 ml	60 ml	125 ml	250 ml	<b>Nr.</b> 220-50020	220-50040	220-50060	220-50080	220-50100
15 ml	30 ml	60 ml	125 ml	250 ml									
<b>Nr.</b> 220-50020	220-50040	220-50060	220-50080	220-50100									
	<b>Doplňovacia guľička</b> pre opätovné naplnenie simalube <b>D</b> G 1/4 <b>Nr.</b> 290-30120		<b>Spätný ventil so zátkou</b> plast <b>Nr.</b> 290-50600										
	<b>Plniaci nástavec</b> do mazacej pištole pre opätovné plnenie simalube <b>D</b> R 1/4   R 3/8 <b>Nr.</b> 290-30130   290-30140		<b>Spätný ventil</b> <b>D</b> G 1/8   G 1/4   G 1/4 <b>Nr.</b> 290-20200   290-20210   290-20230 <b>Bar</b> 0.05   0.05   1.0										

## Ochranné príslušenstvo

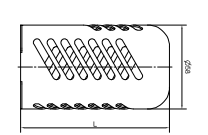
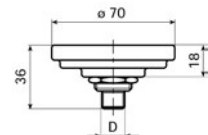
	<b>Ochranný kryt</b> k montážnemu držiakuart. 290-20800 <table border="1"> <tr> <td>30 ml</td> <td>≤125 ml</td> <td>250 ml</td> </tr> <tr> <td><b>L</b> 43</td> <td>105</td> <td>195 [mm]</td> </tr> <tr> <td><b>Nr.</b> 290-20860</td> <td>290-20810</td> <td>290-20850</td> </tr> </table>	30 ml	≤125 ml	250 ml	<b>L</b> 43	105	195 [mm]	<b>Nr.</b> 290-20860	290-20810	290-20850		<b>Montážny držiak</b> pre všetky veľkosti simalube <b>D</b> R 1/4 <b>Nr.</b> 290-20800
30 ml	≤125 ml	250 ml										
<b>L</b> 43	105	195 [mm]										
<b>Nr.</b> 290-20860	290-20810	290-20850										

## Kefky

	<b>Štetce</b> <b>DxL</b>   $\varnothing 25 \times 45$ [mm] <b>Nr.</b>   290-20340		<b>Kefka pre vysoké teploty</b> <b>H</b>   25 [mm] <b>Nr.</b>   290-20500																						
	<b>Štetec krátky</b> <b>DxL</b>   $\varnothing 25 \times 15$ [mm] <b>Nr.</b>   290-20410		<b>Kefka pre vysoké teploty</b> Pripojenie zhora a z boku <table border="1"> <tr> <td><b>H</b></td> <td>40</td> <td>100</td> <td>[mm]</td> </tr> <tr> <td><b>Nr.</b></td> <td>290-20510</td> <td>290-20530</td> <td></td> </tr> </table>	<b>H</b>	40	100	[mm]	<b>Nr.</b>	290-20510	290-20530															
<b>H</b>	40	100	[mm]																						
<b>Nr.</b>	290-20510	290-20530																							
	<b>Kefka</b> FN pre potravinársky priemysel <table border="1"> <tr> <td><b>L</b></td> <td>25</td> <td>40</td> <td>70</td> <td>100</td> <td>[mm]</td> </tr> <tr> <td><b>Nr.</b></td> <td>290-20380</td> <td>290-20350</td> <td>290-20360</td> <td>290-20370</td> <td></td> </tr> <tr> <td><b>Nr.</b></td> <td>290-20385</td> <td>290-20355</td> <td>290-20365</td> <td>290-20375</td> <td></td> </tr> </table>	<b>L</b>	25	40	70	100	[mm]	<b>Nr.</b>	290-20380	290-20350	290-20360	290-20370		<b>Nr.</b>	290-20385	290-20355	290-20365	290-20375			<b>Výfahová kefka</b> <b>Výfahová kefka</b> 5-16 mm, výška 32 mm      16-32 mm, výška 32 mm <table border="1"> <tr> <td><b>Nr.</b></td> <td>290-20390</td> <td><b>Nr.</b></td> <td>290-20440</td> </tr> </table>	<b>Nr.</b>	290-20390	<b>Nr.</b>	290-20440
<b>L</b>	25	40	70	100	[mm]																				
<b>Nr.</b>	290-20380	290-20350	290-20360	290-20370																					
<b>Nr.</b>	290-20385	290-20355	290-20365	290-20375																					
<b>Nr.</b>	290-20390	<b>Nr.</b>	290-20440																						
	<b>Kefka s bočným napojením</b> SFN pre potravinársky priemysel <table border="1"> <tr> <td><b>L</b></td> <td>25</td> <td>40</td> <td>70</td> <td>100</td> </tr> <tr> <td><b>Nr.</b></td> <td>290-20384</td> <td>290-20354</td> <td>290-20364</td> <td>290-20374</td> </tr> <tr> <td><b>Nr.</b></td> <td>290-20357</td> <td>290-20367</td> <td>290-20377</td> <td></td> </tr> </table>	<b>L</b>	25	40	70	100	<b>Nr.</b>	290-20384	290-20354	290-20364	290-20374	<b>Nr.</b>	290-20357	290-20367	290-20377			<b>Výfahová kefka malá</b> 5-16 mm, výška 32 mm <table border="1"> <tr> <td><b>Nr.</b></td> <td>290-20420</td> </tr> </table>	<b>Nr.</b>	290-20420					
<b>L</b>	25	40	70	100																					
<b>Nr.</b>	290-20384	290-20354	290-20364	290-20374																					
<b>Nr.</b>	290-20357	290-20367	290-20377																						
<b>Nr.</b>	290-20420																								

## Montážne príslušenstvo

	<b>a) Hadička</b> <b>b) Hadička pre teploty do 260°C</b> <b>c) Hadička pre malé ohyby</b> <table border="1"> <tr> <td><b>L</b></td> <td>na meter, <math>\varnothing 8/6</math> mm</td> </tr> <tr> <td><b>Nr.</b></td> <td>290-20000/...m   290-20020/...m   290-20040/...m</td> </tr> </table>	<b>L</b>	na meter, $\varnothing 8/6$ mm	<b>Nr.</b>	290-20000/...m   290-20020/...m   290-20040/...m		<b>Dištančný držiak</b> k držiaku nádoby pre kruhový štetec art. 290-20130 <table border="1"> <tr> <td><b>H</b></td> <td>15</td> <td>[mm]</td> </tr> <tr> <td><b>Nr.</b></td> <td>290-20140</td> <td></td> </tr> </table>	<b>H</b>	15	[mm]	<b>Nr.</b>	290-20140															
<b>L</b>	na meter, $\varnothing 8/6$ mm																										
<b>Nr.</b>	290-20000/...m   290-20020/...m   290-20040/...m																										
<b>H</b>	15	[mm]																									
<b>Nr.</b>	290-20140																										
	<b>Fixačná objímka pre simalube/štetec</b> plast <table border="1"> <tr> <td><b>D</b></td> <td>22 (SL 15 ml)</td> <td>28 (Brush)</td> <td>50 (SL 30-250 ml)</td> <td>[mm]</td> </tr> <tr> <td><b>Nr.</b></td> <td>290-20150</td> <td>290-20130</td> <td>290-20100</td> <td></td> </tr> </table>	<b>D</b>	22 (SL 15 ml)	28 (Brush)	50 (SL 30-250 ml)	[mm]	<b>Nr.</b>	290-20150	290-20130	290-20100			<b>Upevňovací uholník</b> k montážnemu držiaku simalube art. 290-20800 <table border="1"> <tr> <td></td> <td>1x</td> <td>3x</td> <td>5x</td> </tr> <tr> <td><b>L</b></td> <td>75</td> <td>240</td> <td>390</td> <td>[mm]</td> </tr> <tr> <td><b>Nr.</b></td> <td>290-20820</td> <td>290-20830</td> <td>290-20840</td> <td></td> </tr> </table>		1x	3x	5x	<b>L</b>	75	240	390	[mm]	<b>Nr.</b>	290-20820	290-20830	290-20840	
<b>D</b>	22 (SL 15 ml)	28 (Brush)	50 (SL 30-250 ml)	[mm]																							
<b>Nr.</b>	290-20150	290-20130	290-20100																								
	1x	3x	5x																								
<b>L</b>	75	240	390	[mm]																							
<b>Nr.</b>	290-20820	290-20830	290-20840																								
	<b>Magnetický držiak</b> pre fixačnú objímku <b>Nr.</b>   290-20190		<b>Malá konzola "L"</b> pre simalube 15-60 ml <b>Nr.</b>   290-20870																								
	<b>Adaptér pre nádobku (60mm)</b> plast <table border="1"> <tr> <td><b>D</b></td> <td>50</td> <td>[mm]</td> </tr> <tr> <td><b>Nr.</b></td> <td>290-20120</td> <td></td> </tr> </table>	<b>D</b>	50	[mm]	<b>Nr.</b>	290-20120			<b>Držiak univerzálny</b> nastaviteľný <b>Nr.</b>   290-28000																		
<b>D</b>	50	[mm]																									
<b>Nr.</b>	290-20120																										

## Montážne dielce simalube multipoint

	<b>Quick connection</b> pre hadičku $\varnothing 4$ mm <table border="1"> <tr> <td><b>D</b></td> <td>G 1/8</td> <td>G 1/4</td> <td>M 5</td> <td>M 6</td> </tr> <tr> <td><b>Nr.</b></td> <td>290-11700</td> <td>290-11710</td> <td>290-11720</td> <td>290-11730</td> </tr> </table>	<b>D</b>	G 1/8	G 1/4	M 5	M 6	<b>Nr.</b>	290-11700	290-11710	290-11720	290-11730		<b>Hadička</b> k dispozícii v metroch <table border="1"> <tr> <td><b>L</b></td> <td>na meter</td> <td><math>\varnothing 4/2,7</math> mm</td> </tr> <tr> <td><b>Nr.</b></td> <td>290-21000/...m</td> <td></td> </tr> </table>	<b>L</b>	na meter	$\varnothing 4/2,7$ mm	<b>Nr.</b>	290-21000/...m	
<b>D</b>	G 1/8	G 1/4	M 5	M 6															
<b>Nr.</b>	290-11700	290-11710	290-11720	290-11730															
<b>L</b>	na meter	$\varnothing 4/2,7$ mm																	
<b>Nr.</b>	290-21000/...m																		
	<b>Pripojovací kus SLM</b> <table border="1"> <tr> <td><b>D</b></td> <td>5x <math>\varnothing 4</math> mm</td> </tr> <tr> <td><b>Nr.</b></td> <td>290-29000</td> </tr> </table>	<b>D</b>	5x $\varnothing 4$ mm	<b>Nr.</b>	290-29000														
<b>D</b>	5x $\varnothing 4$ mm																		
<b>Nr.</b>	290-29000																		

## Kartuše s mazacím tukom a nádoby s olejom na predmazanie

	<b>Kartuša s mazacím tukom 400 ml</b> <table border="1"> <tr> <td></td> <td>SL01</td> <td>SL02</td> <td>SL04</td> <td>SL06</td> <td>SL09</td> </tr> <tr> <td><b>Nr.</b></td> <td>290-70010</td> <td>290-70020</td> <td>290-70040</td> <td>290-70060</td> <td>290-70090</td> </tr> <tr> <td></td> <td>SL10</td> <td>SL12</td> <td>SL24</td> <td>SL25</td> <td>SL26</td> </tr> <tr> <td><b>Nr.</b></td> <td>290-70100</td> <td>290-70120</td> <td>290-70240</td> <td>290-70250</td> <td>290-70260</td> </tr> </table>		SL01	SL02	SL04	SL06	SL09	<b>Nr.</b>	290-70010	290-70020	290-70040	290-70060	290-70090		SL10	SL12	SL24	SL25	SL26	<b>Nr.</b>	290-70100	290-70120	290-70240	290-70250	290-70260		<b>Nádobka s mazacím olejom 0,5 l</b> <table border="1"> <tr> <td></td> <td>SL14</td> <td>SL15</td> <td>SL16</td> <td>SL18</td> <td>SL19</td> </tr> <tr> <td><b>Nr.</b></td> <td>290-71140</td> <td>290-71150</td> <td>290-71160</td> <td>290-71180</td> <td>290-71190</td> </tr> </table>		SL14	SL15	SL16	SL18	SL19	<b>Nr.</b>	290-71140	290-71150	290-71160	290-71180	290-71190
	SL01	SL02	SL04	SL06	SL09																																		
<b>Nr.</b>	290-70010	290-70020	290-70040	290-70060	290-70090																																		
	SL10	SL12	SL24	SL25	SL26																																		
<b>Nr.</b>	290-70100	290-70120	290-70240	290-70250	290-70260																																		
	SL14	SL15	SL16	SL18	SL19																																		
<b>Nr.</b>	290-71140	290-71150	290-71160	290-71180	290-71190																																		

## Príslušenstvo k simalube IMPULSE

	<b>simalube IMPULSE connect</b> násobič tlaku <b>Nr.</b>   230-10100		<b>Blok batérií</b> <table border="1"> <tr> <td><b>Power</b></td> <td>6 V 2,3 Ah</td> </tr> <tr> <td><b>Nr.</b></td> <td>230-50000</td> </tr> </table>	<b>Power</b>	6 V 2,3 Ah	<b>Nr.</b>	230-50000
<b>Power</b>	6 V 2,3 Ah						
<b>Nr.</b>	230-50000						